

Gecko and Fly on a Wall

by Herman van Goubergen

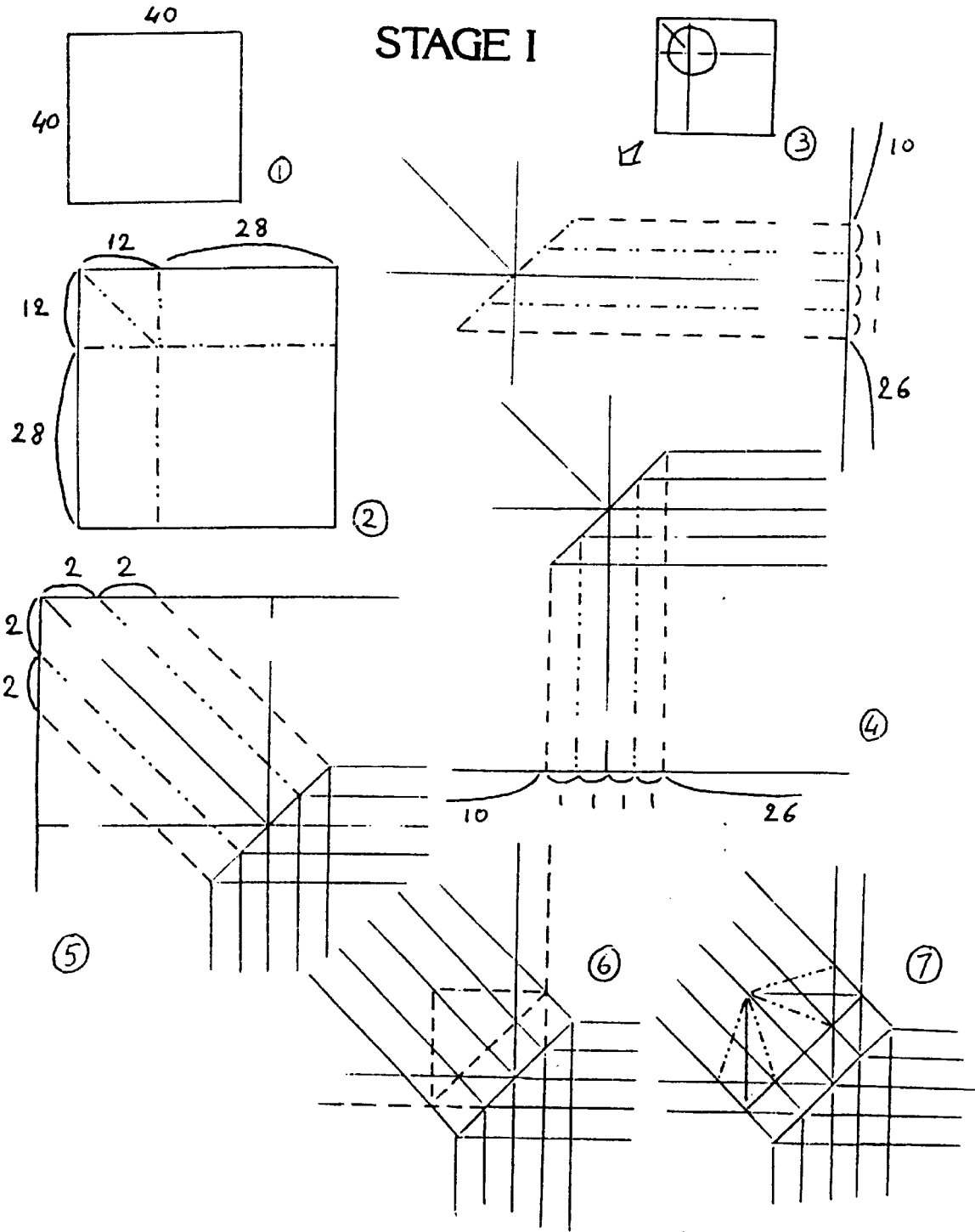

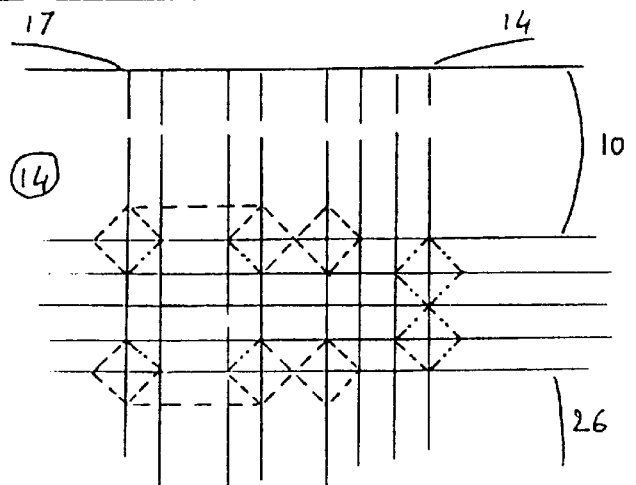
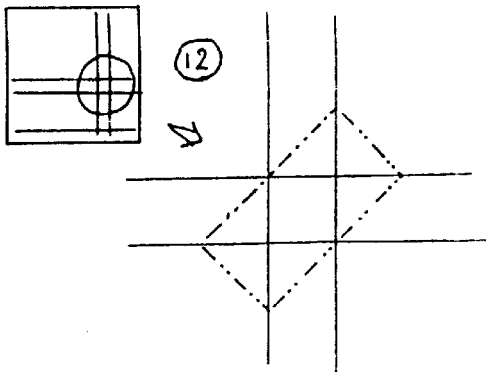
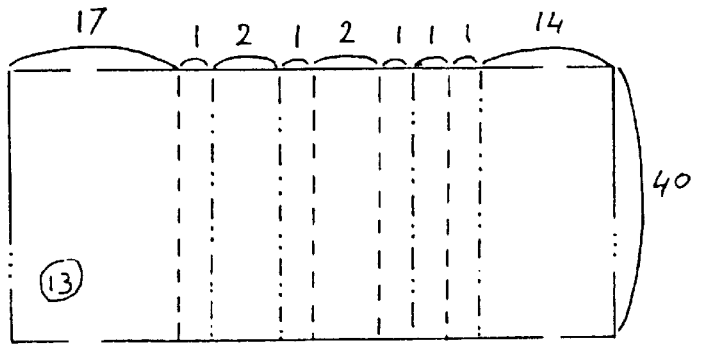
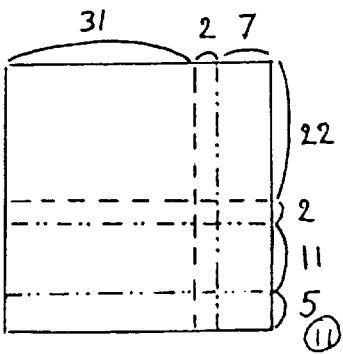
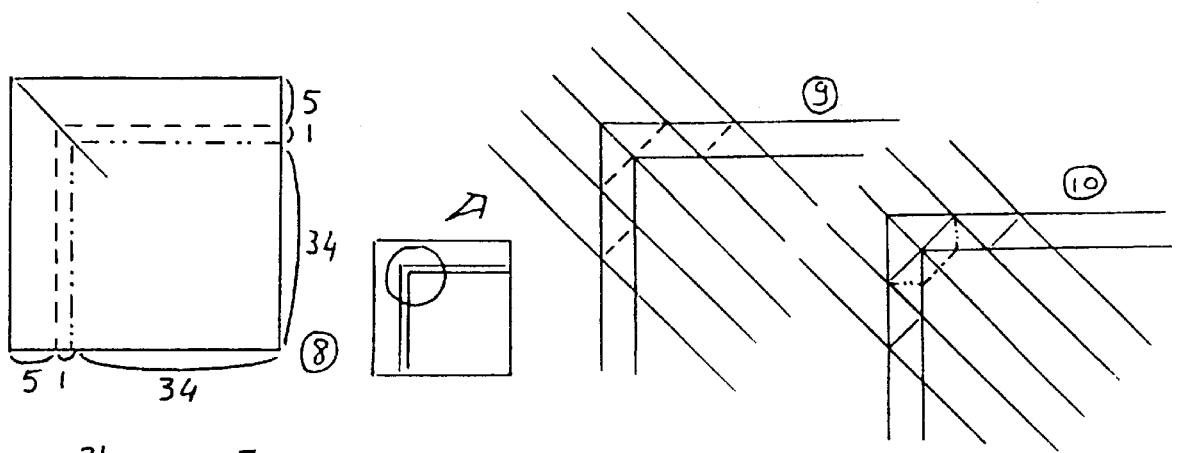

STAGE II

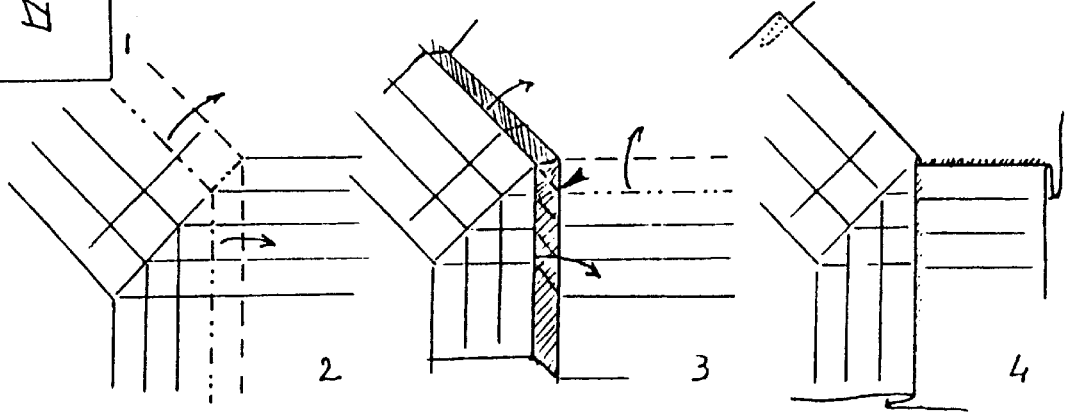
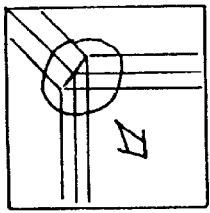

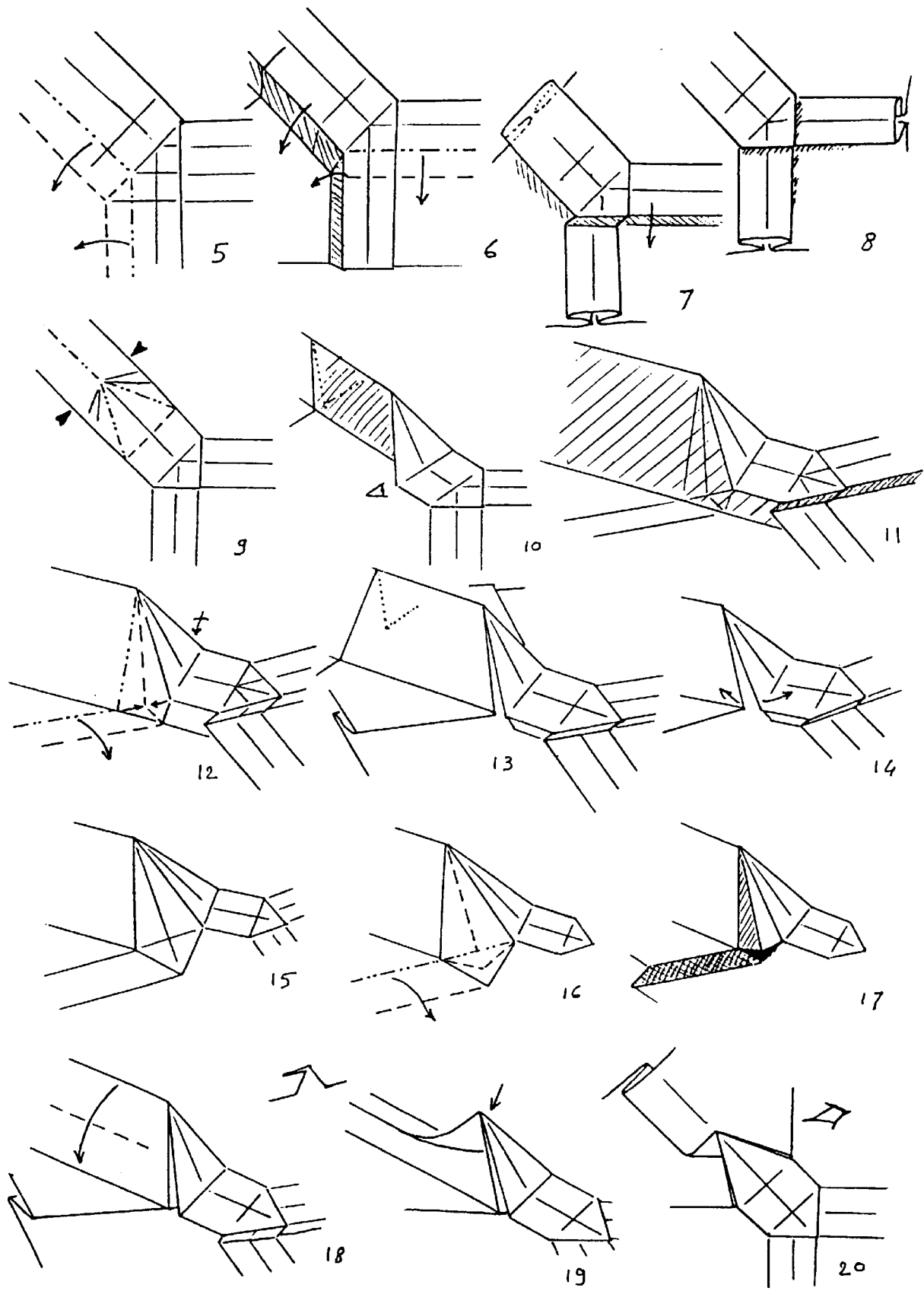

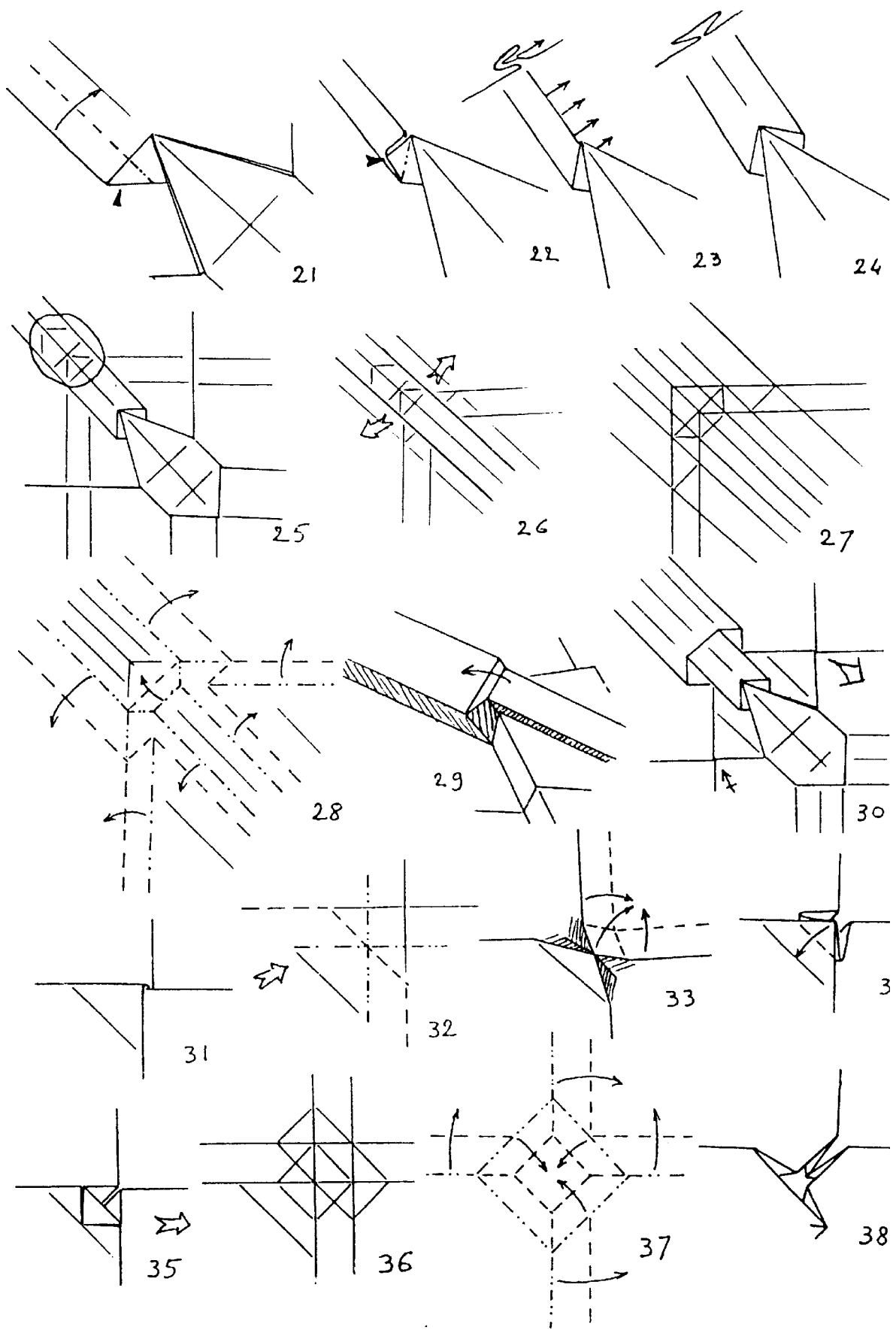

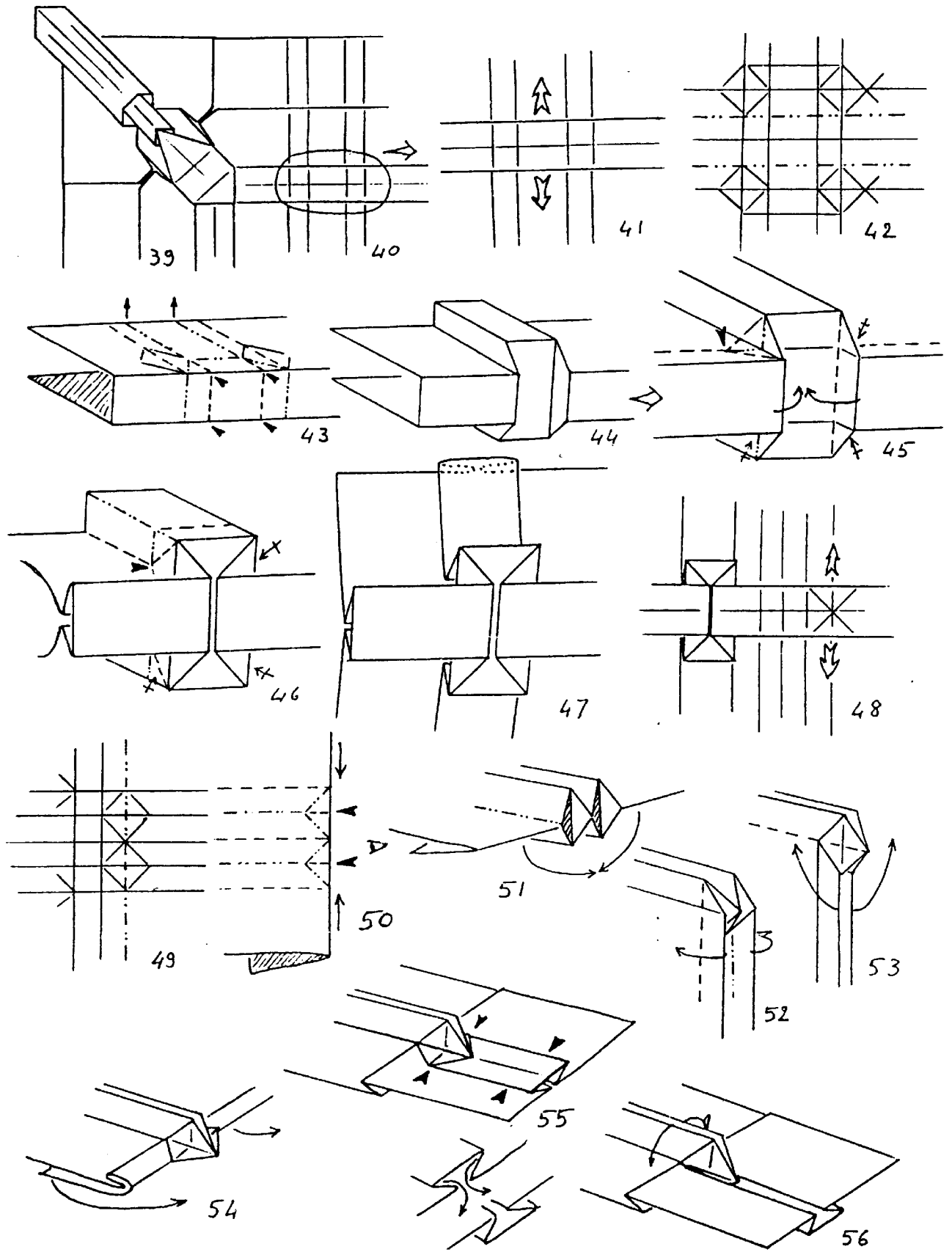

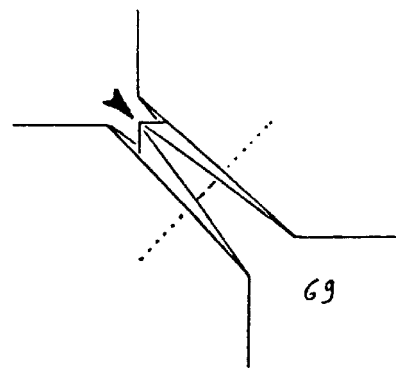
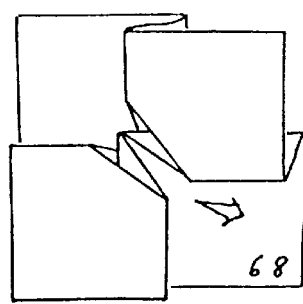
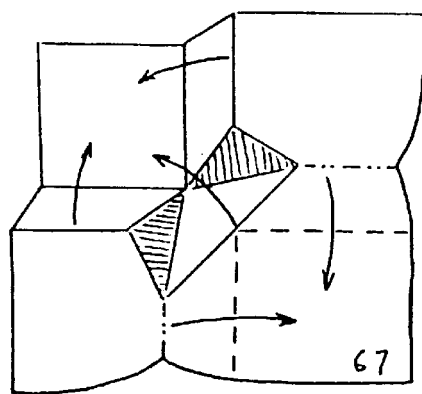
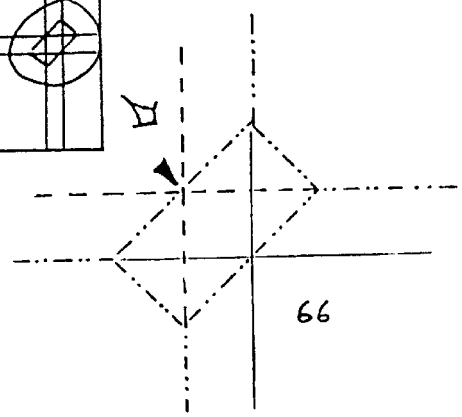
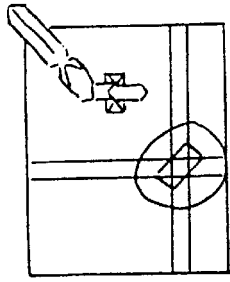
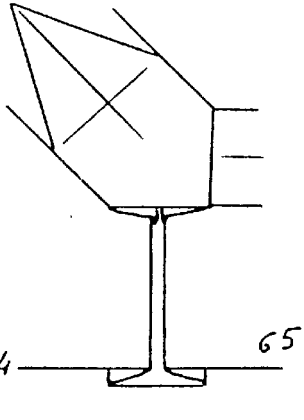
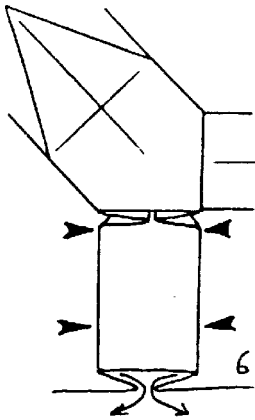
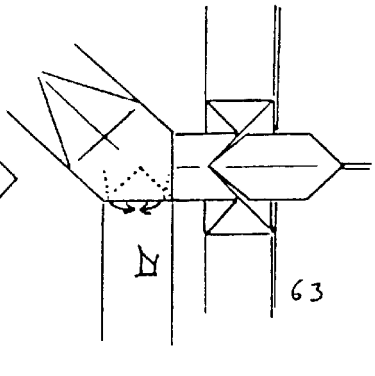
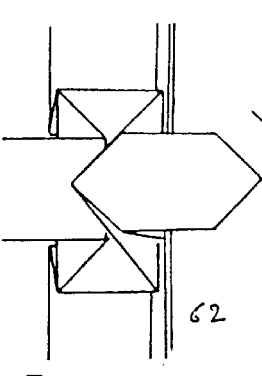
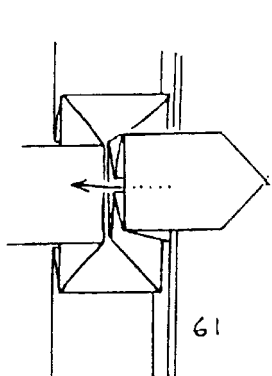
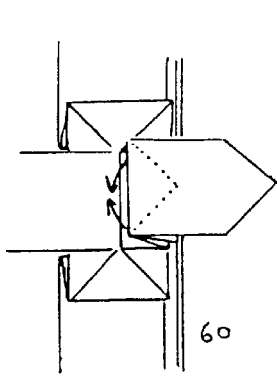
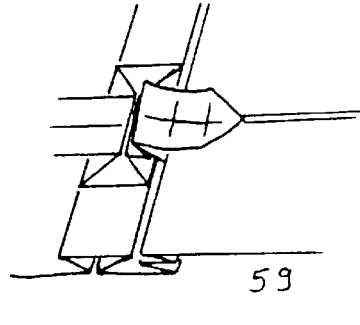
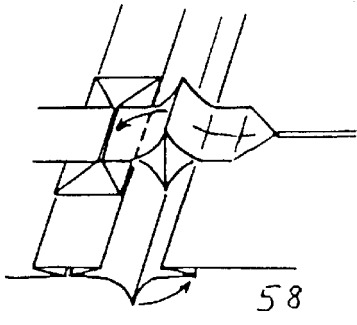
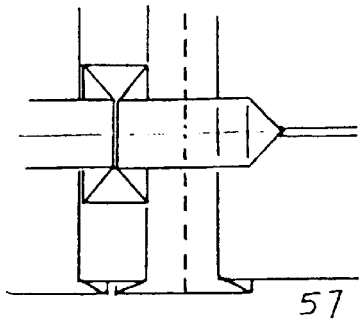

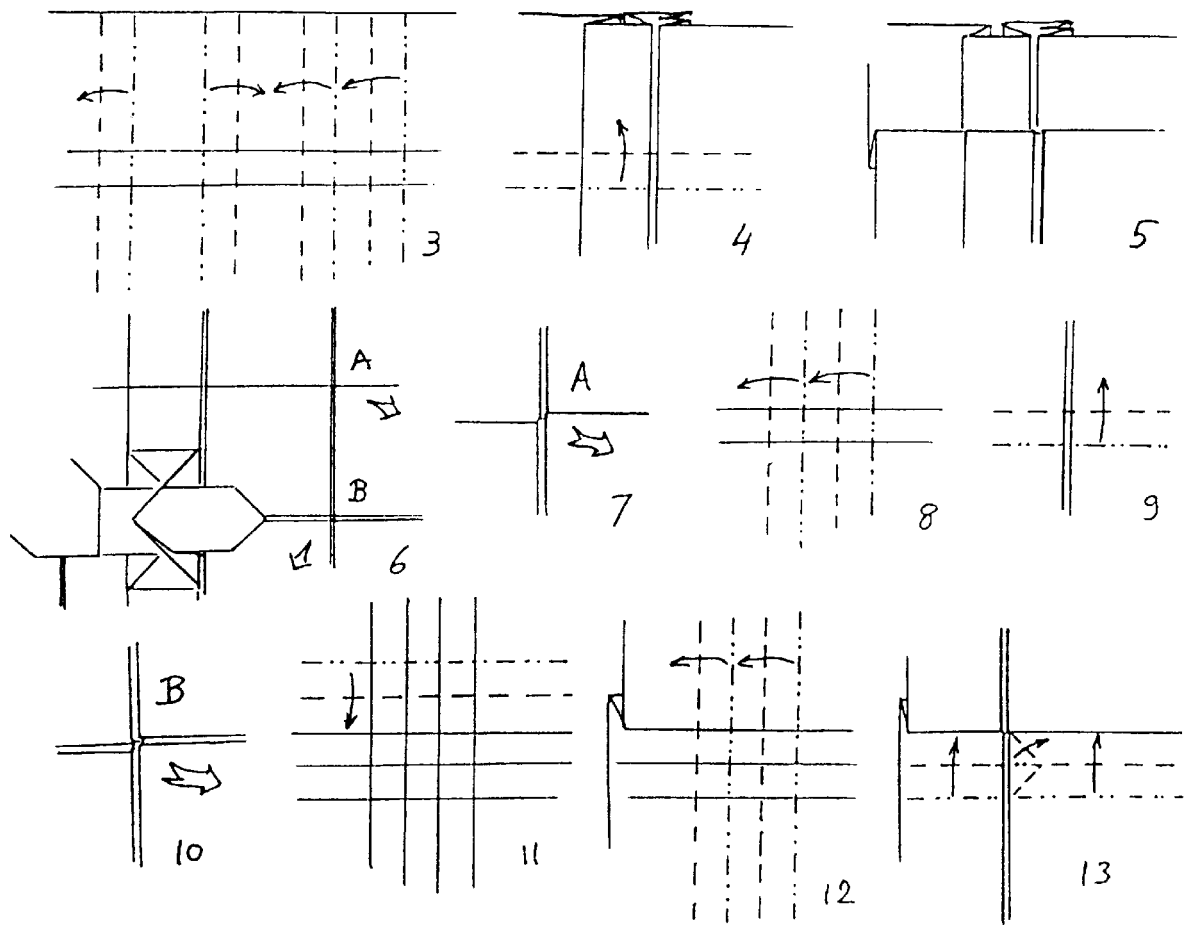
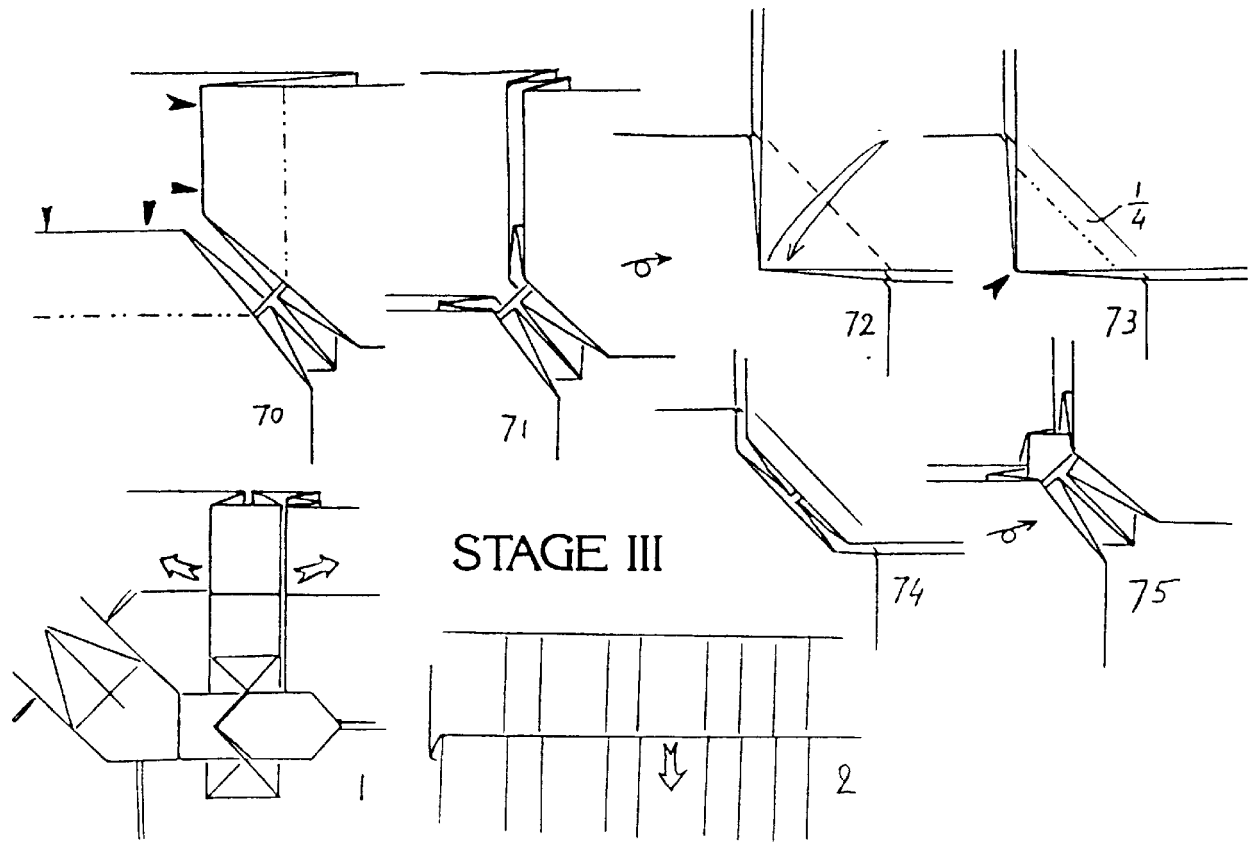

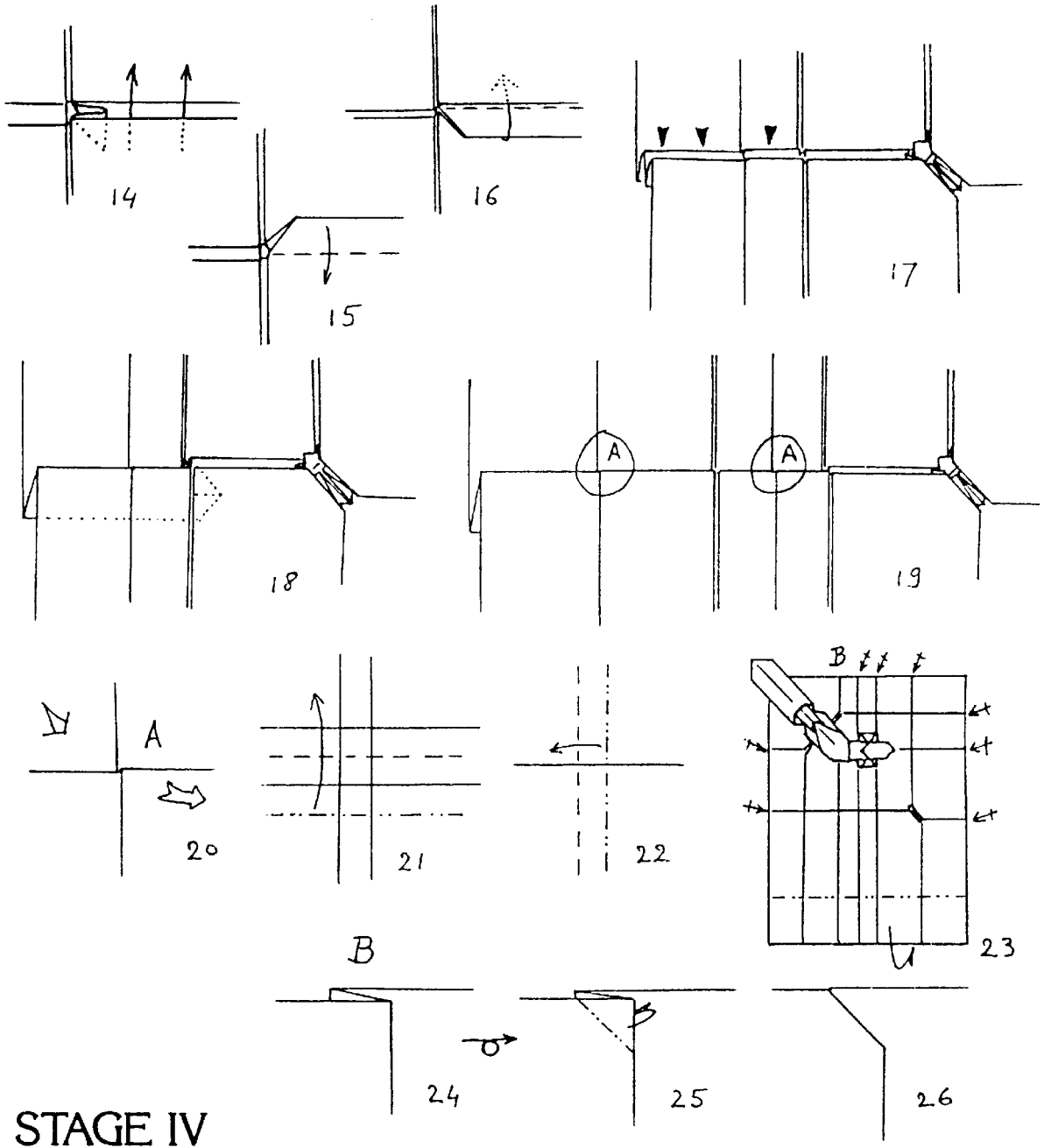

STAGE IV

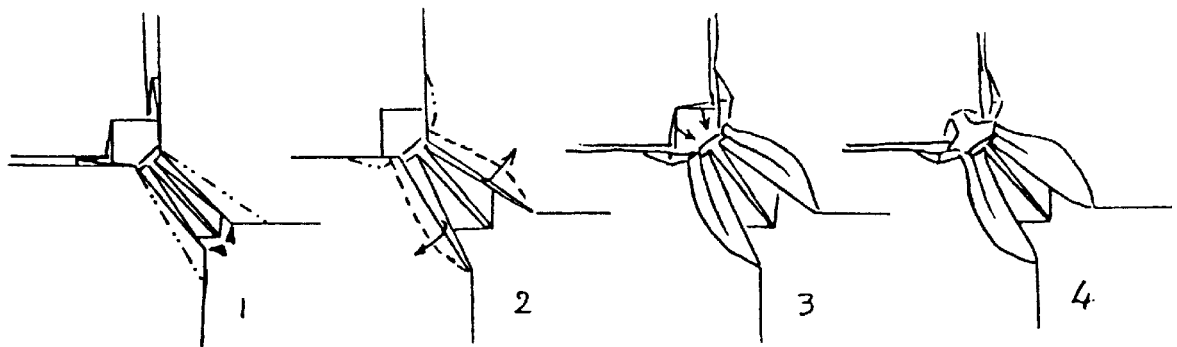

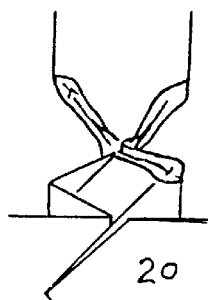
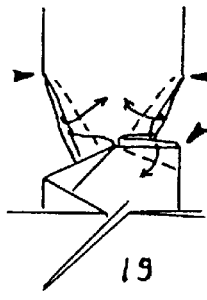
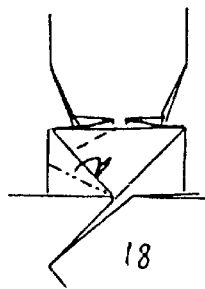
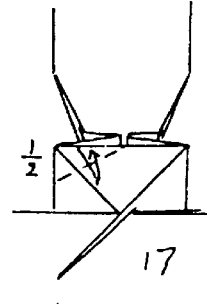
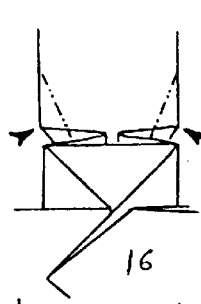
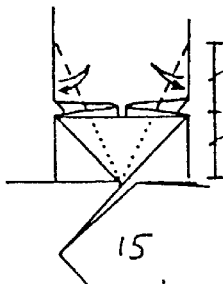
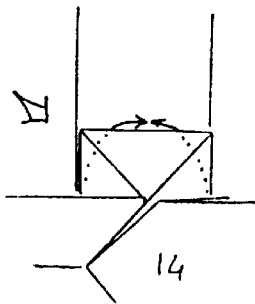
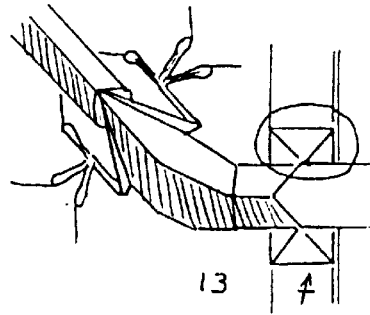
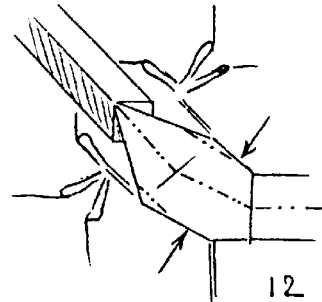
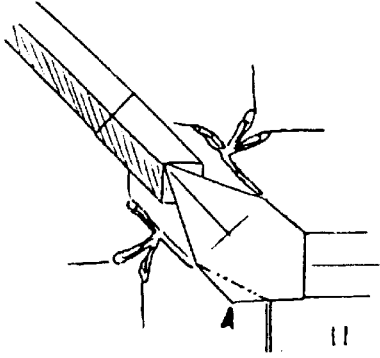
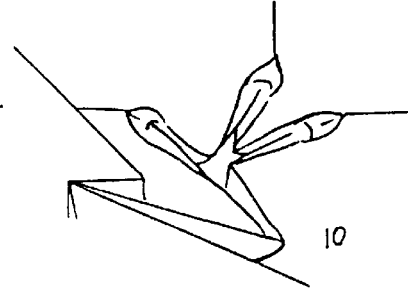
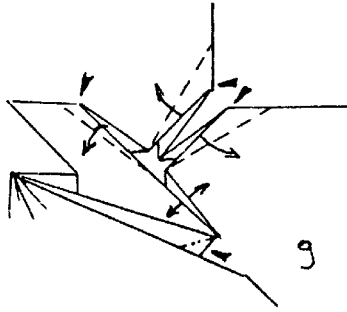
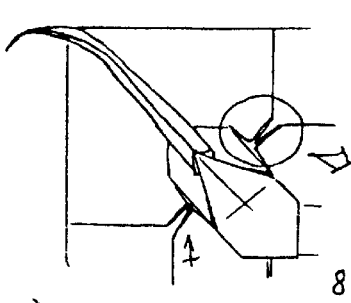
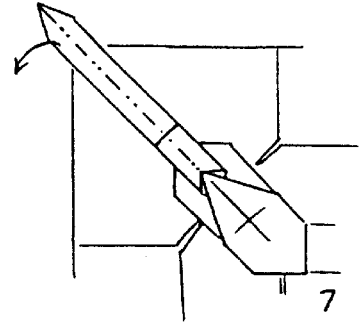
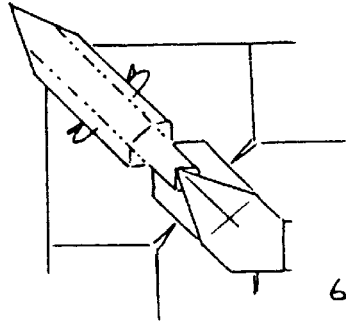
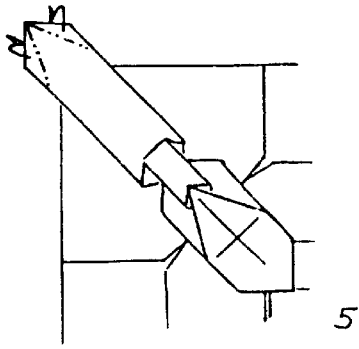

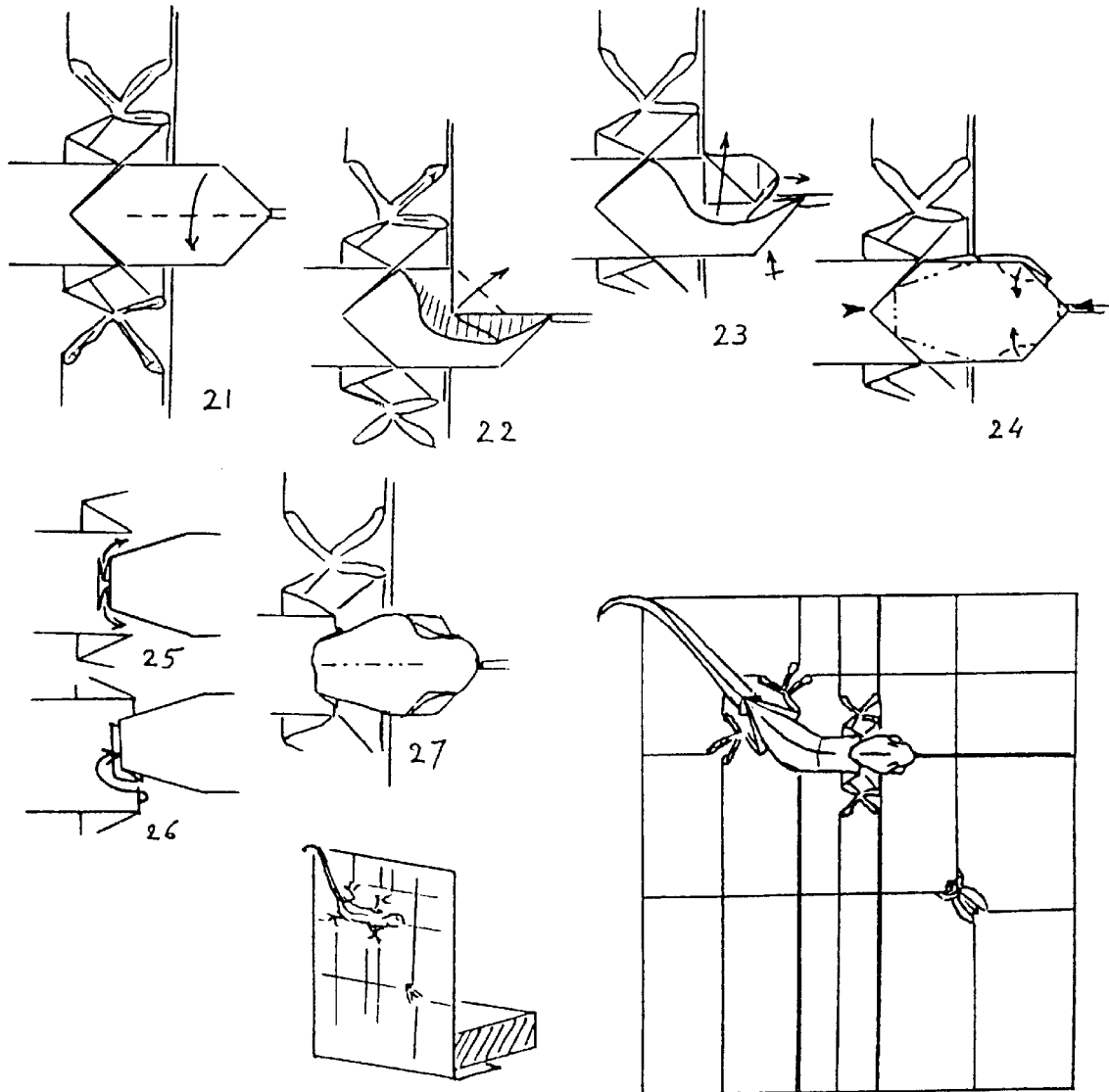

© HERMAN VAN GOUBERGEN 93-94

Instructions

Use a large square (I use a 30×30 cm piece of Kraft paper).

The distances around the edges of the paper are measured in units of 1/40th of the side of the square. The final model is 22 by 25 units.

stage 1: precreasing. Measure the correct position for the long folds and draw them on the back of the paper before folding.

stage 2: collapsing. To do some manoeuvres, you may have to undo previous folds.

stage 3: rearranging. Where the long pleats cross,

they tend to open out. To avoid this, the pleat sequence is rearranged locally to lock the pleats. After this stage (or after stage 4) it is a good idea to put some heavy books on the 'wall' portions of the model and leave it overnight to get a nice flat background.

stage 4: final modelling. Fold the details and 3D the lizard. Give it a nice curved shape.

You can either stand the model as indicated in the drawing (if the paper is stiff enough) or hang it on the wall.

Copyright © 1993–1994 Herman van Goubergen, all rights reserved.
 PDF version 1999 by Sebastian Marius Kirsch <skirsch@t-online.de>.
 Distribution for noncommercial purposes is free. Please contact the author if you want to use this model for commercial purposes.